



Echo Comfort 170 Kitchen Mixer

Product Image

Product Details



Code:	KM422655LFB
Brand:	Argent
Range:	Echo Comfort
Warranty:	15 Years*
WELS:	5 Star 6.0 LPM, Reg #: T37600

Additional Features

Technical Specification

Required Product

Recommended Products

Additional Notes

- AS1428 Dimensionally Compliant
- Extended Lever For Easy Reach
- Red and Blue Indicators
- 360 Swivel Spout
- Quality Pex Hoses

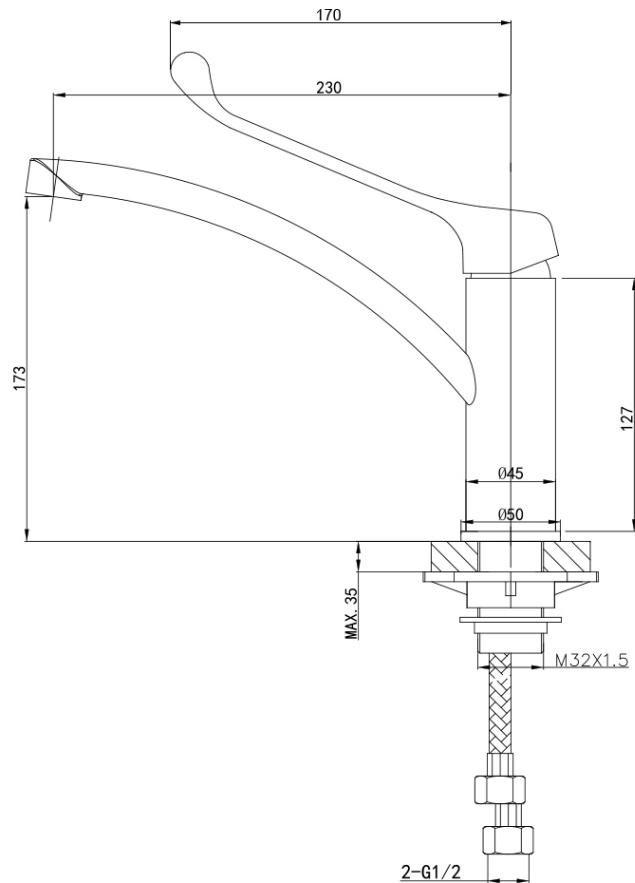

*Please visit argentaust.com.au/warranty to view the full warranty

Note: All dimensions are in millimetres and are subject to normal manufacturing variations. Always use the physical product measurements for cut-outs and rough-ins as the technical details shown may differ from the actual product. Use acetic cured silicone sealant. Do not use epoxy type adhesives. Clean with damp cloth. Do not use abrasive cleaners, liquids or pastes.

